

ITEM NO.	PART NUMBER	QTY.
1	washer_m10	3
2	18 MAIN-TOPPLATE_x1_12mm_FERRO	1
3	Main endpanel Assembly	2
4	Stationary knife array Assembly	2
5	binding_rod_m12	3
6	01 MAIN-BASEPLATE_x1_15mm_FERRO	1
7	spur_gear_mod5_17t_p85_od95_id40_fw50	2
8	Motor mount Assembly	1
9	Shaft and blade assembly	1
10	Shaft and blade assembly slave	1
11	Side Assembly	2
12	16 BEARING-HOUSING-ENDCAP_x1_2mm_INOX	1
13	14 MOTOR-PACKER_x4_10mm_FERRO	4
14	Motor bay Assembly	1
15	Sieve assembly	1

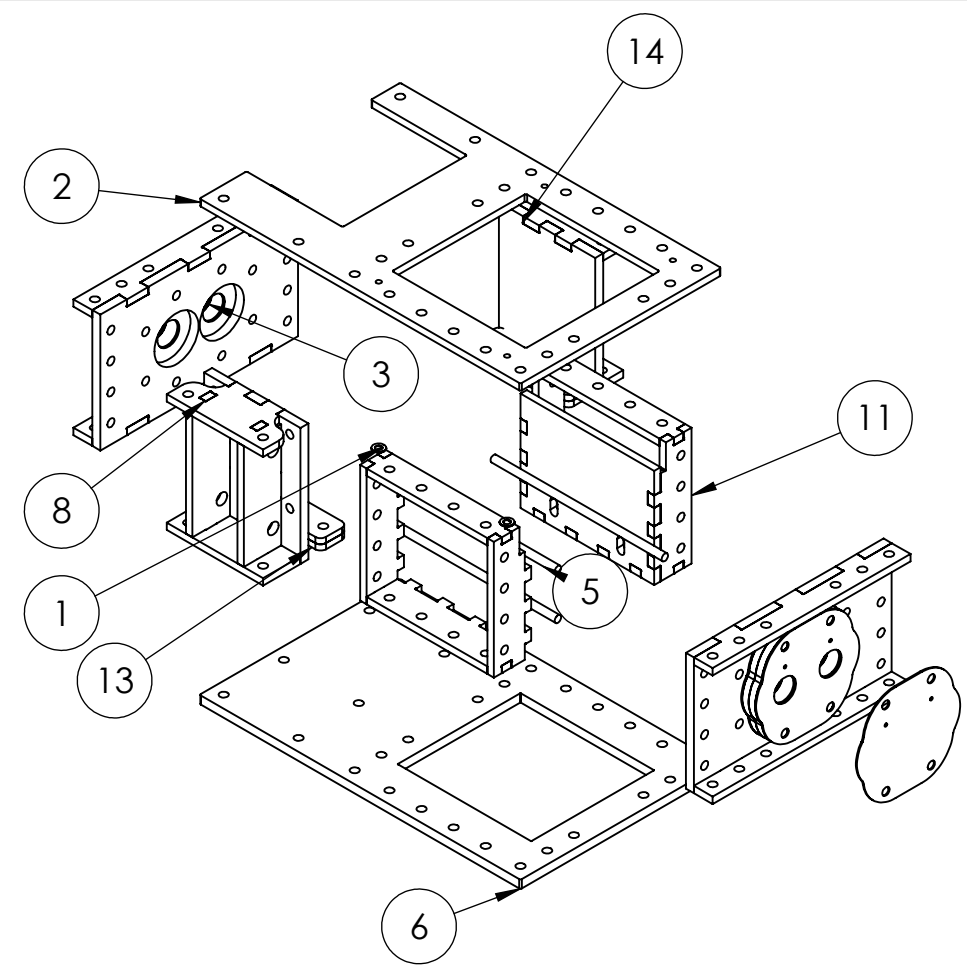

UNLESS OTHERWISE SPECIFIED: DIMENSIONS ARE IN MILLIMETERS SURFACE FINISH: TOLERANCES: LINEAR: ANGULAR:			FINISH:		DEBURR AND BREAK SHARP EDGES		DO NOT SCALE DRAWING		REVISION		
DRAWN			NAME		SIGNATURE		DATE		TITLE:		
CHK'D											
APPV'D											
MFG											
Q.A							MATERIAL:		DWG NO.		
									100_ShredderBoxAssembly		
							WEIGHT:		SCALE:1:20		
									SHEET 1 OF 1		

100\_ShredderBoxAssembly

A4