

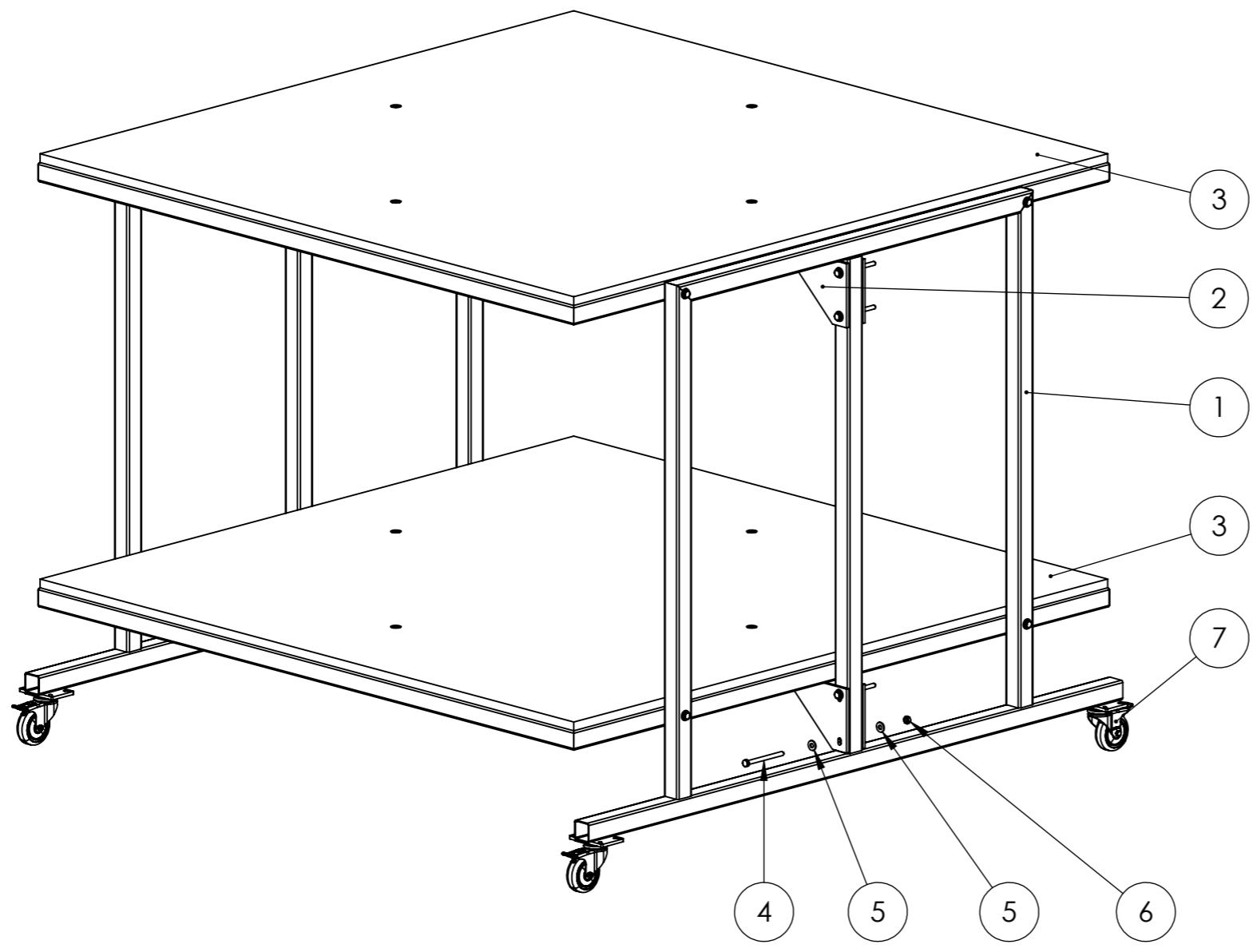

8 7 6 5 4 3 2 1

F  
E  
D  
C  
B  
A

F  
E  
D  
C  
B  
A



7	4	Caster	Supplied
6	24	Hex nut M8	
5	48	Flat washer M8	
4	24	Hex bolt M8x100mm	
3	2	Tier assembly	PT-V2 10.00-B
2	8	Gusset	PT-V2 00.02-B
1	2	Side frame	PT-V2 00.01-B
ITEM NO.	QTY	DESCRIPTION	PART NO.

	Machine		Description			
	<b>Prep Table</b>		<b>Prep table assembly</b>			
	Projection method: <b>First angle</b>		Release date <b>09/2020</b>	Drawing no. <b>PT-V2 00.00-B</b>		Rev. <b>1</b>
General tolerances <b>ISO 2768-m</b>		Doc. type <b>Assembly</b>	Units unless specified <b>mm</b>	Sheet size <b>A3</b>	Scale <b>1:12</b>	Sheet <b>1/6</b>

8 7 6 5 4 3 2 1