



Arbor - Injection - 'Elena'

Perfect for more complicated molds and better production rates as well good quality with high precision. Easy to transport and ideal for a educational context and small enterprises.

Specifications

Type	Manual Injection
Version	1.4
Status	Mature
Weight	40 KG
Dimensions	Packaged : 50cm x 15 cm x 110cm Assembled : 1.6m x 20 cm x 1.1m
Voltage	110V / 220V
Flake size:	Small to Medium
Shot size	350 mm (barrel length) x 25 mm (barrel diameter) : 0.17 Liter 171.81 cm ³ 150 gramm (PP)
License	CERN Open Source Hardware License
Authors	PlasticHub S.L.

Resources

[3D Preview](#)

[Wiki](#)

[Download](#)

Details

Dimensions

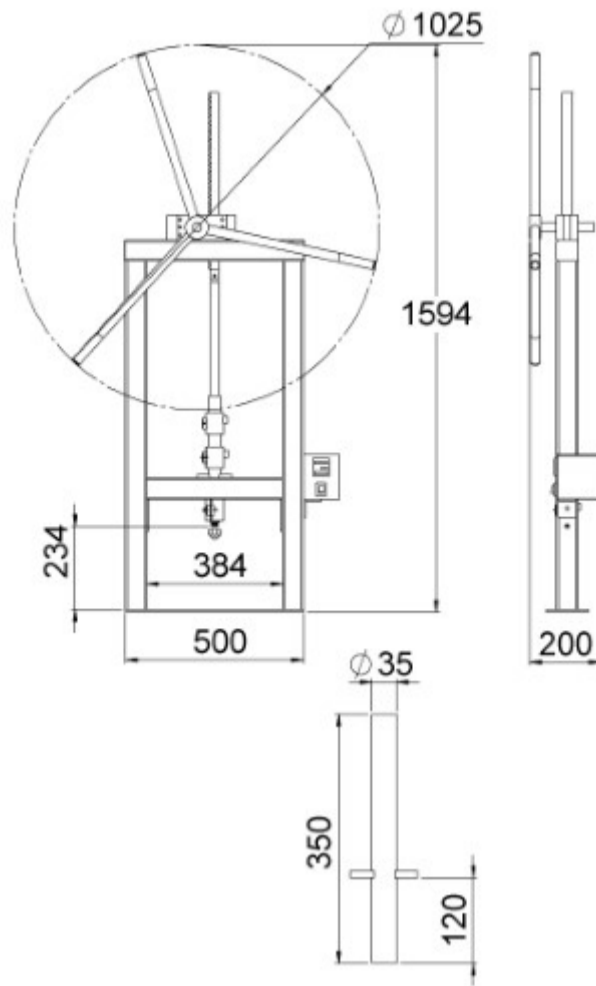

[Download Drawing](#)

Components

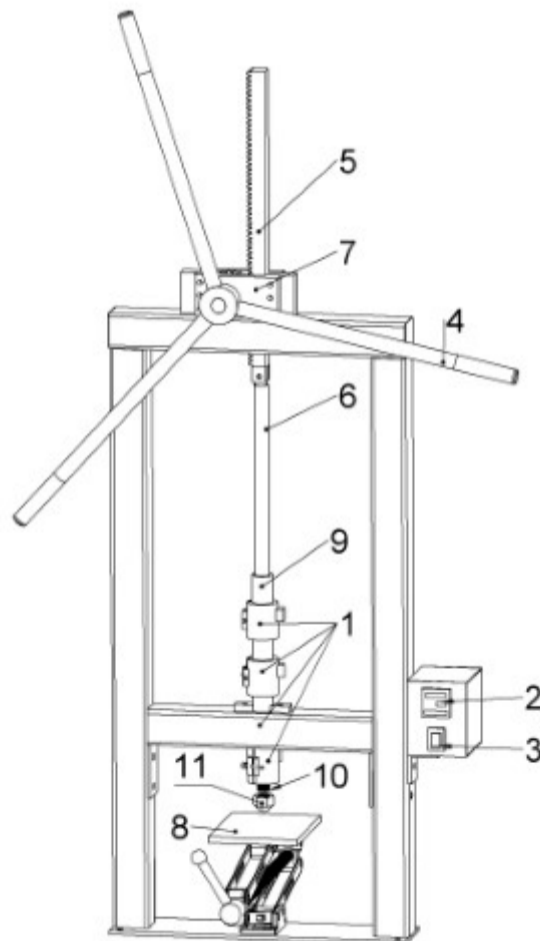

[Download Drawing](#)

Part Nr.	Description	Configuration
1	Heatbands	250W – 220V 110V OD:35mm Height : 6cm
2	PID Controller	InkBird 100-VH
3	Power Switch	IP55 Grade
4	Solid Round Bar	25mm diameter / 50 cm long
5	Rack	Module-3 3cm x 3 cm x 50 cm
6	Plunger	25mm diameter / 38 cm long
7	Gear Brackets	14 cm x 2 cm x 7 cm Aluminium 25 mm Bushing
8	Car – Jack	20 x 15 cm Mould Plate
9	Barrel	35cm ID: 25 mm OD: 35 mm
10	Nozzle Interface	M20 / 12 mm bore
11	Nozzle	M20 / 12 mm bore with inset cone

Performance
